

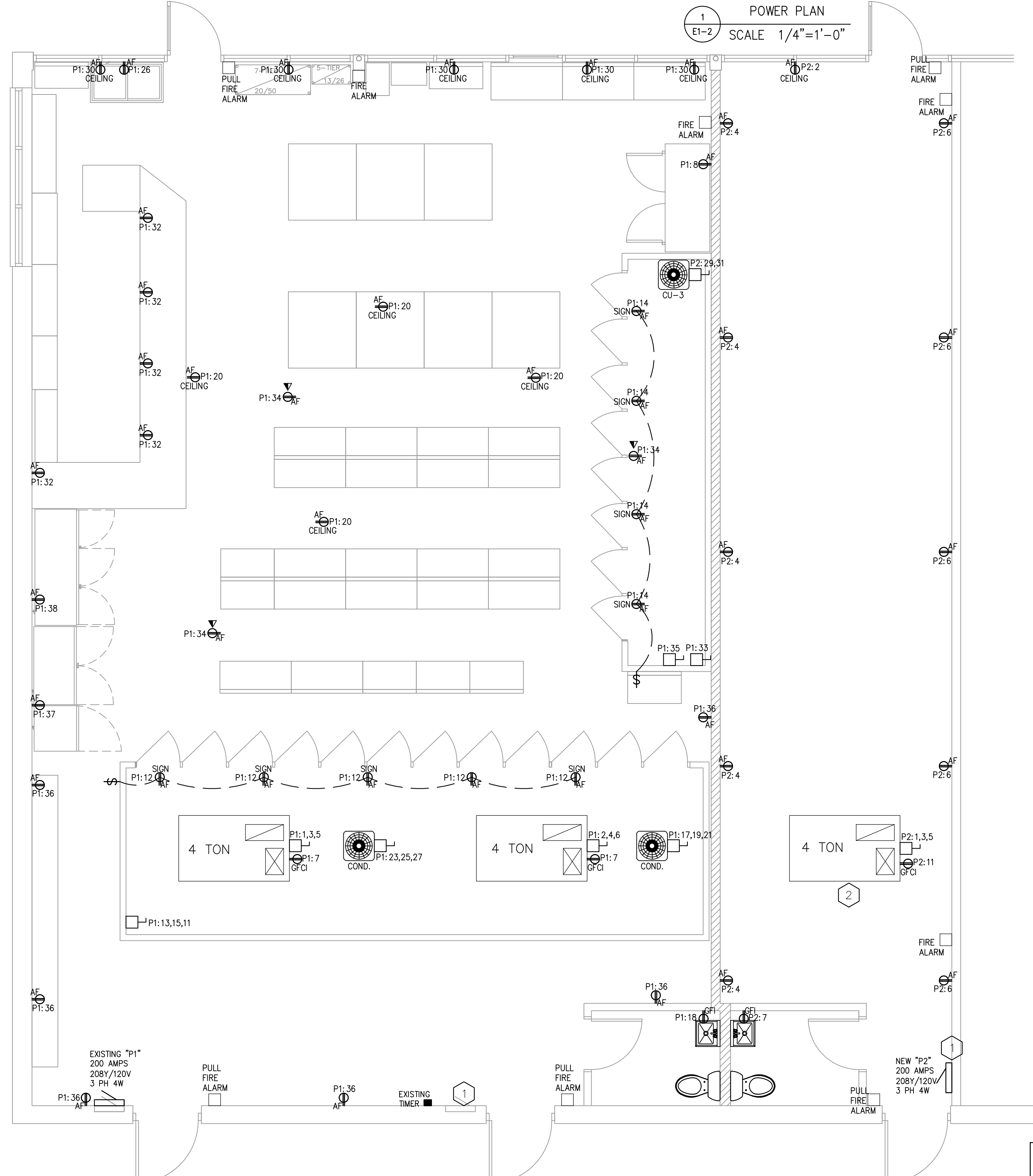

5725 WEST HENDERSON ST
CHICAGO IL 60634
TEL. (432) 528-0511
FAX. (432) 528-0511
ELECTRICVOLT@GMAIL.COM

NEW DISMISSING WALL EXISTING LIQUOR STORE
WEST CHICAGO, ILLINOIS

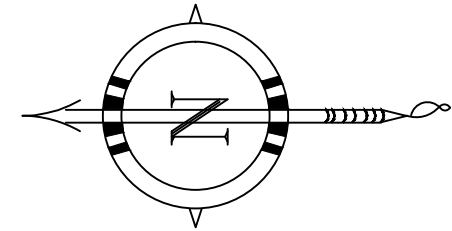

DESCRIPTION	VA			BRANCH CIRCUIT			LUG LOCATION MOUNTING			BOTTOM FLUSH			K.A.I.C. TYPE			DESCRIPTION				
	A	B	C	Ø	NEUT	GND	COND	P	TR	CKT #	A	P	COND	GND	NEUT		Ø	A	B	C
	RTU-1	2000	2000		3 #8	--	10	3/4"	3	40	1 2 3 4 5 6	40	3	3/4"	10		--	3 #8	2000	2000

DESCRIPTION	VA			BRANCH CIRCUIT			LUG LOCATION MOUNTING			BOTTOM FLUSH			K.A.I.C. TYPE			DESCRIPTION								
	A	B	C	Ø	NEUT	GND	COND	P	TR	CKT NO	A	P	COND	GND	NEUT		Ø	A	B	C				
	RTU-3	2000	2000		3 #8	--	10	3/4"	3	40	1 2 3 4 5 6 7 8 9 10 11 12 13 14 15 16 17 18 19 20 21 22 23 24 25 26 27 28 29 30 31 32 33 34 35 36 37 38 39 40 41 42	40	3	3/4"	12		12	12	12	12	12	12	180	900

NOTES:

- E.C. SHALL VERIFY ALL REQUIREMENTS WITH POWER COMPANY PRIOR TO START OF PROJECT AND TO FURNISH AND INSTALL ALL MATERIAL AND LABOR AS REQUIRED FOR A COMPLETE AND OPERATIONAL SYSTEM.
- MINIMUM WITHSTAND RATING FOR SWITCHBOARD SHALL BE 100,000 AIC FULLY RATED. E.C. SHALL VERIFY WITH POWER COMPANY AVAILABLE FAULT CURRENT AND INCREASE WITHSTAND RATING ABOVE AIC IF NECESSARY.

KEY NOTES #

- REMOVE THE 200 AMP PANEL, FOR THE NEW LOCATION;
- THE NEW PANEL MUST CONNECT TO THE CEILING UNIT WITH DISCONNECT, PROVIDE A GFCI OUTLET;

CONDUIT NOTES:

- FOR UNDERGROUND INSTALLATION USE GALVANIZED RIGID CONDUIT "RMC", FOR ABOVE GROUND USE ELECTRIC METALLIC TUBING "EMT"
- CONDUIT TYPE "EMT" MAXIMUM FILL TO 40% OF CONDUIT AREA FOR 4 OR MORE CONDUCTORS. FOR TWO CONDUCTORS FILL TO 31% CONDUIT AREA
- MAXIMUM 360° BEND BETWEEN PULL POINTS.
- FOR #8 CONDUIT & WIRE #12 AWG MAX. 9 WIRES, FOR #8 AWG MAX. 3 WIRES.
- FOR #6 CONDUIT & WIRE #12 AWG MAX. 16 WIRES, FOR #8 AWG MAX. 5 WIRES.

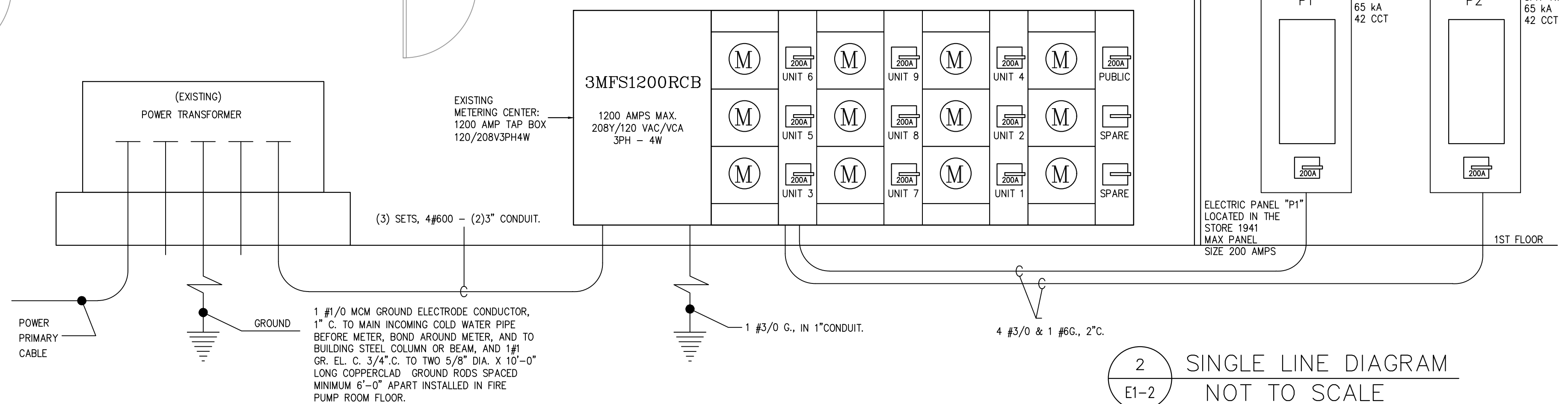

2 SINGLE LINE DIAGRAM NOT TO SCALE

I HEREBY CERTIFY THAT THIS PLANS WERE PREPARED UNDER MY SUPERVISION AND TO THE BEST OF MY KNOWLEDGE COMPLY WITH THE CITY OF WEST CHICAGO BUILDING CODE AND ORDINANCES.

PROJECT NO.	8003	SHEET NO.	E1-2
DATE	01/17/2024		
1 FOR LANDLORD APPROVAL 1/22/2024			
NO.	REVISIONS	DATE	
DSGN.	HB	CHKD.	HB
DWN.	HB		
SCALE: AS SHOWN			
SHEET TITLE : POWER PLAN			